

REVISIONS				
ZONE	REV	DESCRIPTION	DATE	APPROVED
	A	NEW DRAWING RELEASE PER DMD DMR	8-13-04	MEI

IMPEDANCE: 50 OHMS NOMINAL
 FREQUENCY RANGE: DC TO 2.5GHz
 VSWR: DC TO 1GHz AT 1.10:1 MAX.
 1GHz TO 2.5 GHz AT 1.25:1 MAX.
 POWER RATING: 500 WATTS AVG. (UNI-DIRECTIONAL) AT 25°C AMBIENT
 DERATED LINEARLY TO 50 WATTS AT 125°C.
 COOLING FIN: ALUMINUM, BLACK ANODIZED
 COVER: ALUMINUM, BLACK ANODIZED
 CONNECTORS: "QC" BNC FEMALE
 OPERATING POSITION: ANY POSITION EXCEPT MOUNTING SURFACE UP
 NOMINAL SIZE: APPROX. 11.75" L X 5.40" W X 4.80" H
 WEIGHT: APPROX. 7.9 LBS

D

C

B

A

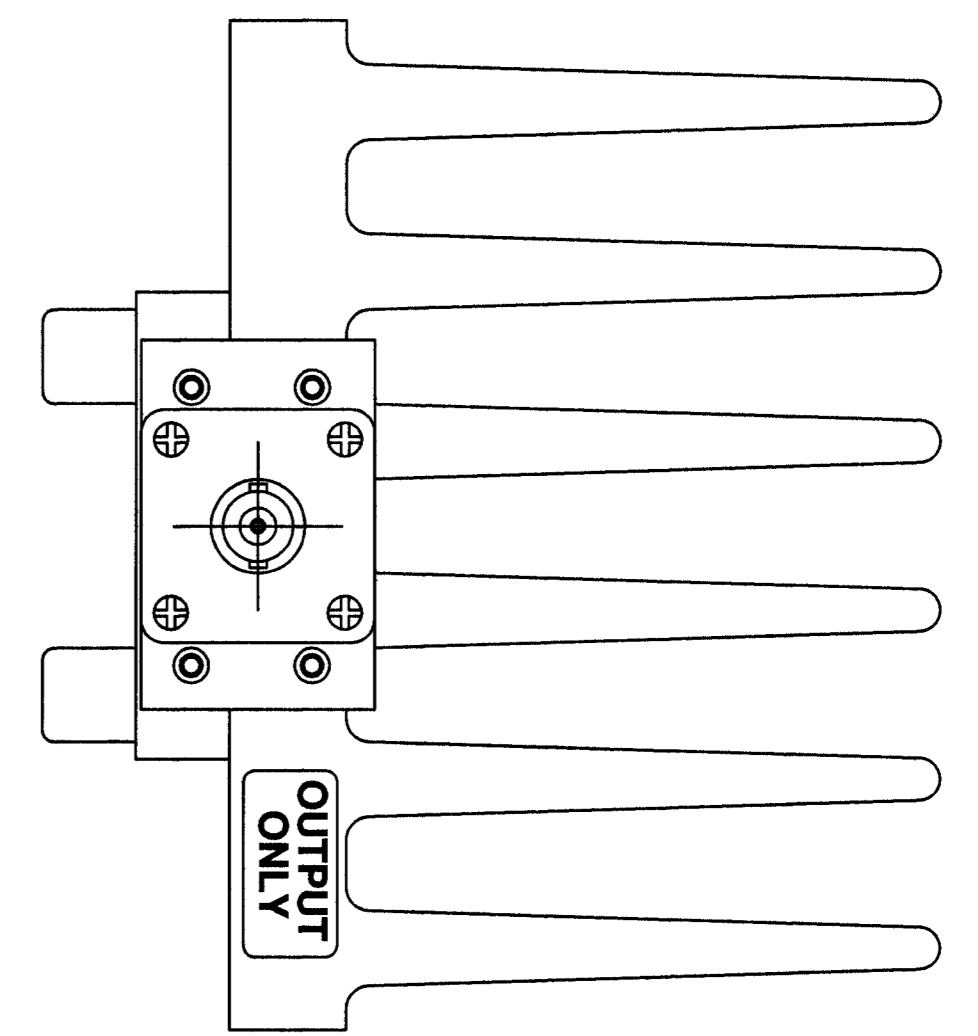
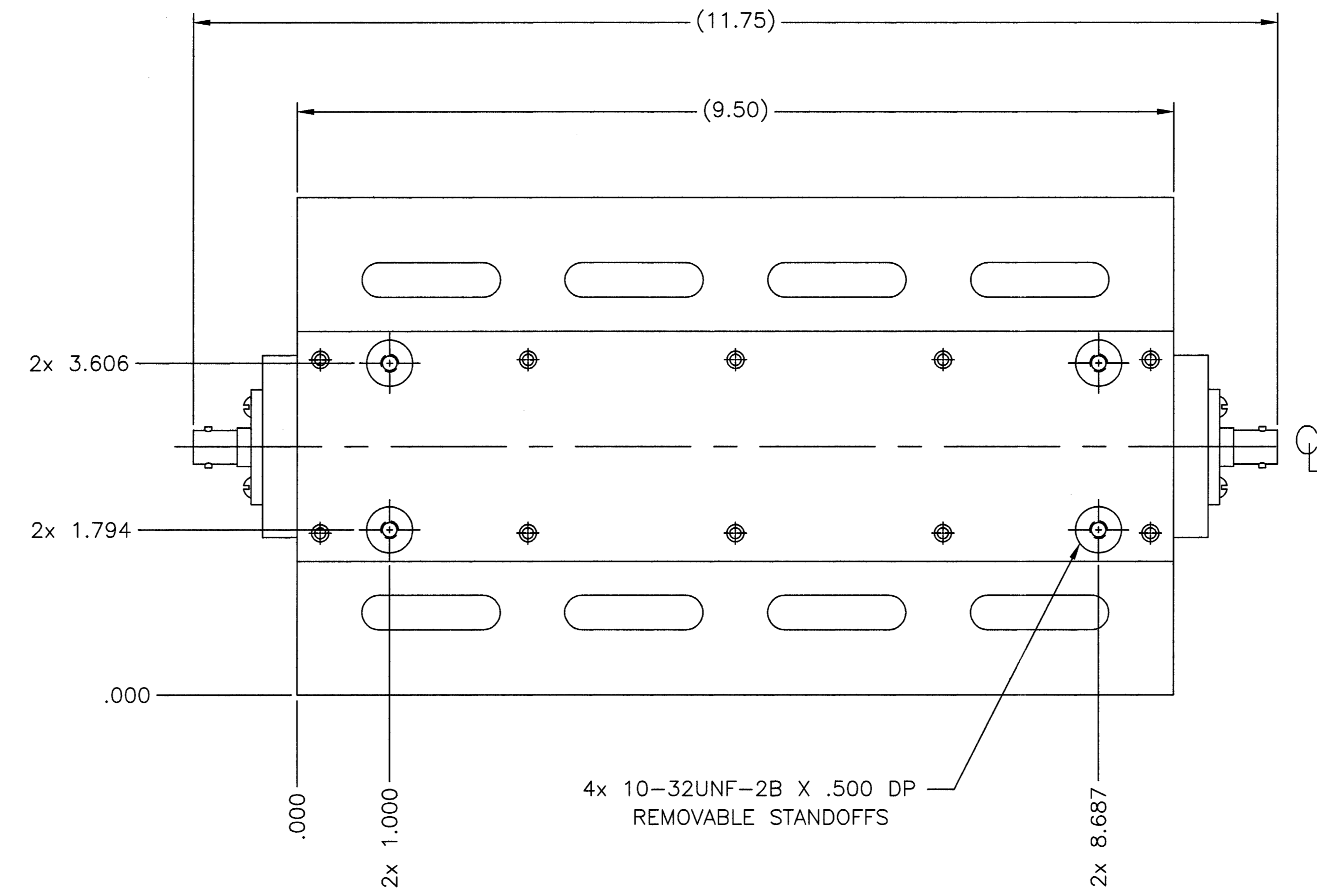
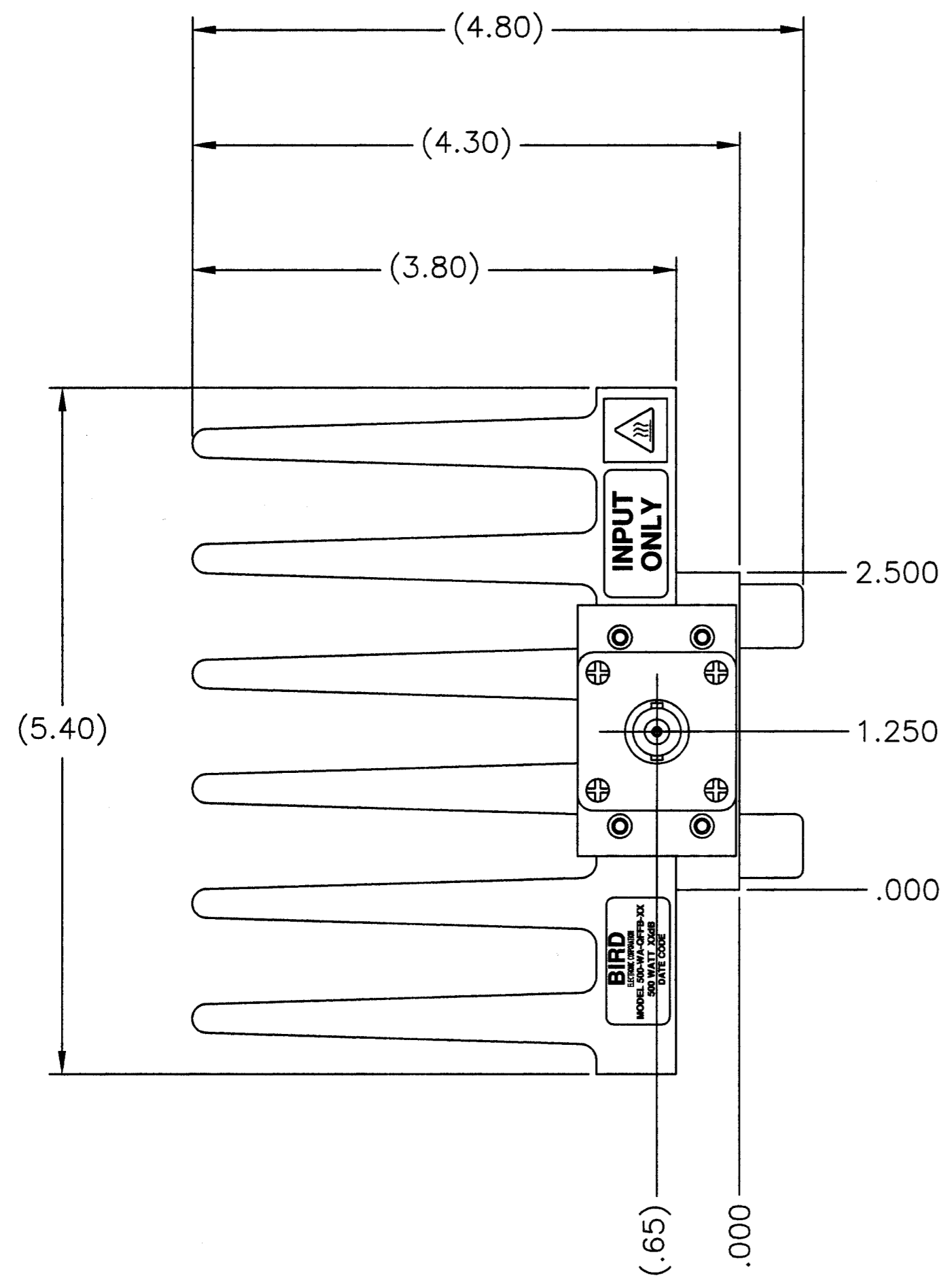

DIMENSIONS ARE IN INCHES UNLESS OTHERWISE SPECIFIED

XX = DASH NUMBER (dB VALUE)

-30	30	±0.8 dB	±1.3 dB
-20	20	±0.5 dB	±1.0 dB
-10	10	±0.4 dB	±0.8 dB
-06	6	±0.4 dB	±0.6 dB
-03	3	±0.3 dB	±0.5 dB
DASH NO.	dB ATTEN.	ATTENUATOR DC - 1GHz	ACCURACY ±dB 1 - 2.5GHz

NOTE:
 FOR VALUES NOT LISTED, REFER TO THE NEXT HIGHER ATTENUATION LEVEL FOR SPECIFICATIONS.
 FOR ATTENUATION VALUES GREATER THAN THE HIGHEST LISTED ATTENUATION VALUE, REFER TO THE VALUE 1/2 THE DESIRED ATTENUATION LEVEL, THEN DOUBLE THE LISTED SPECIFICATION VALUES, UNLESS OTHERWISE SPECIFIED.

DIMENSIONS HEREON ARE FOR CUSTOMER CONVENIENCE AND REFERENCE ONLY. TOLERANCE TO BE APPLIED ONLY WHERE INDIVIDUALLY STATED ON THE RESPECTIVE DIMENSION. -DO NOT SCALE DRAWING-

<small>UNLESS OTHERWISE SPECIFIED DIMENSIONS ARE IN INCHES TOLERANCES ARE:</small> <small>FRACTIONS DECIMALS ANGLES</small> <small>± 1/64 .005 ± .010 ± 30°</small> <small>DO NOT SCALE DRAWING</small>		<small>MILLIMETERS</small> <small>30 ± .4</small> <small>± .12</small>		<small>THIS DRAWING IS THE PROPERTY OF THE BIRD ELECTRONIC CORPORATION. THE DESIGNS AND SPECIFICATIONS DISCLOSED HEREON ARE PROPRIETARY AND SHALL NOT BE REPRODUCED, NOR COPIED, NOR USED AS THE BASIS FOR THE MANUFACTURE OR SALE OF APPARATUS OR DEVICES WITHOUT THEIR EXPRESS WRITTEN CONSENT.</small>			
<small>APPROVALS</small> <small>DRAWN D.M.RINK</small> <small>CHECKED</small> <small>APPROVED</small>		<small>DATE</small> <small>8-11-04</small> <small>8-11-04</small>		<small>TITLE</small> <small>ATTENUATOR, CONVECTION COOLED "QC" BNC FEMALE, 500W</small>		<small>SIZE</small> <small>D</small>	
<small>MATERIAL</small> <small>FINISH</small>		<small>SCALE</small> <small>1:1</small>		<small>DWG. NO.</small> <small>70998</small>		<small>REV</small> <small>A</small>	
		<small>COM CODE</small> <small>AT1</small>		<small>SHEET</small> <small>1 OF 1</small>			

8

7

6

5

4

3

2

1